

## Data sheet - SO4-M3-10

### Self-clinching standoffs for stainless steel and other sheet metals

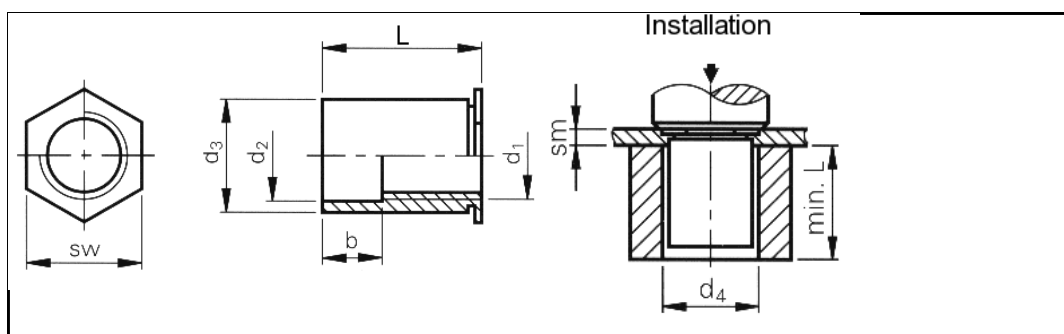

3D-Data available	
Order description	SO4-M3-10
Thread d1	M3
Hole-Ø in the sheet +0.08 0	4.2 mm
d2 ±0.13	3.25 mm
d3 0 -0.13	4.20 mm
d4	4.4 mm
sw	4.8 mm
Min. sm	1.0 mm
L +0.05 -0.13	10 mm
Length without threads b ±0.25	4 mm
Min. edge distance up to the hole centre	6.0 mm
Material	Passivated stainless steel (AISI 400).
Use	For sheet hardnesses up to HRB 88.
Tools	
Insertion machines	

uniform resource locator: