

## Data sheet - BSO4-M3-10

### Blind self-clinching standoffs for stainless steel and other sheet metals

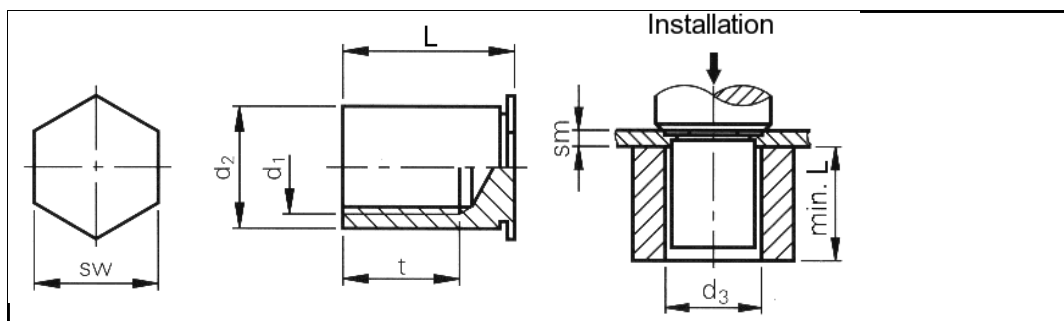

3D-Data available	
Order description	BSO4-M3-10
Thread d1	M3
Hole-Ø in the sheet +0.08 0	4.2 mm
d2 0 -0.13	4.20 mm
d3	4.4 mm
sw	4.8 mm
Min. sm	1.0 mm
L +0.05 -0.13	10 mm
Depth of thread tmin.	4 mm
Min. edge distance up to the hole centre	6.0 mm
Material	Passivated stainless steel (AISI 400).
Use	For sheet hardnesses up to HRB 88.
Tools	
Insertion machines	

uniform resource locator: