

Data sheet - FHLS-M5-12

Self-clinching flush head low displacement studs

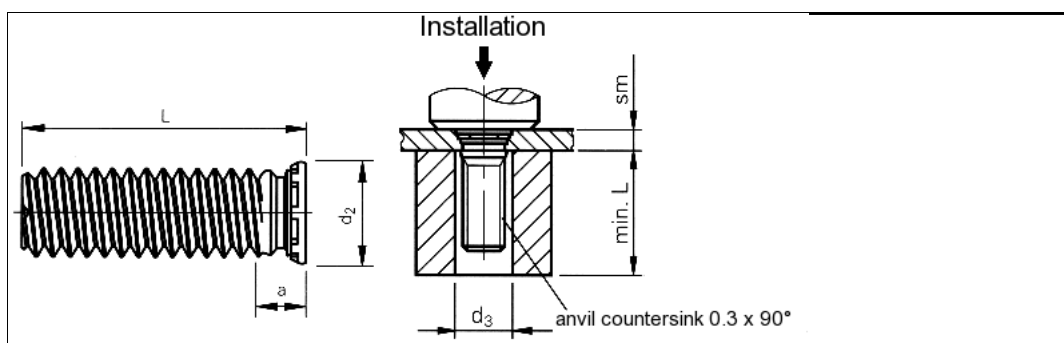

3D-Data available	
Order description	FHLS-M5-12
Thread d1	M5
Hole-Ø in the sheet +0.08 0	5.0 mm
d2 ±0.4	5.9 mm
d3	5.1 mm
Max. a	2.7 mm
Min. sm	1.0 mm
L ±0.4	12 mm
Min. edge distance up to the hole centre	5.6 mm
Material	Passivated grade 18/8 stainless steel (AISI 300).
Use	For sheet hardnesses up to HRB 70.
Tools	
Insertion machines	

uniform resource locator: